

PMA Systems Ltd.



Company data

- Name: PMA Systems Kft.
- Seat: H-9026 Győr, Bácsai u. 148/C.
- Site: H-9027 Győr, Kandó Kálmán utca 7.
- Web: www.pmasystems.hu
- E-mail: info@pmagroup.hu
- Year of foundation: 2017



Activities

- Planning and implementation of hand stations
- Planning and implementation of semiautomatic equipment
- Planning and implementation of automatic systems
- Planning and implementation of robot cells
- Individual and mass production of parts
- Planning and production of appliances
- Planning and implementation of pneumatic, hydraulic systems
- Electrical tasks [planning and implementation]
- Maintenance, restoration of tools [cutting, punching tools, injection molding tools]
- Completion, reconstruction of existing production equipment
- PLC programming
- Locksmith tasks
- Maintenance tasks
- Systemintegration

Portfolio

Please have a look at some examples of our work

Reference equipment

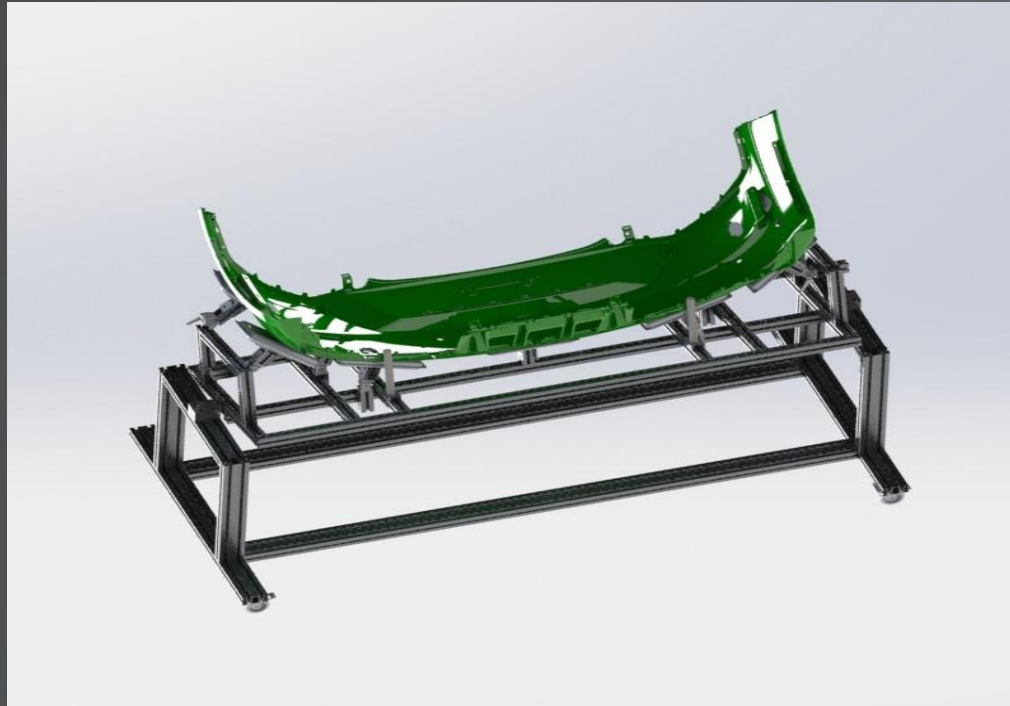

Workpiece carrier

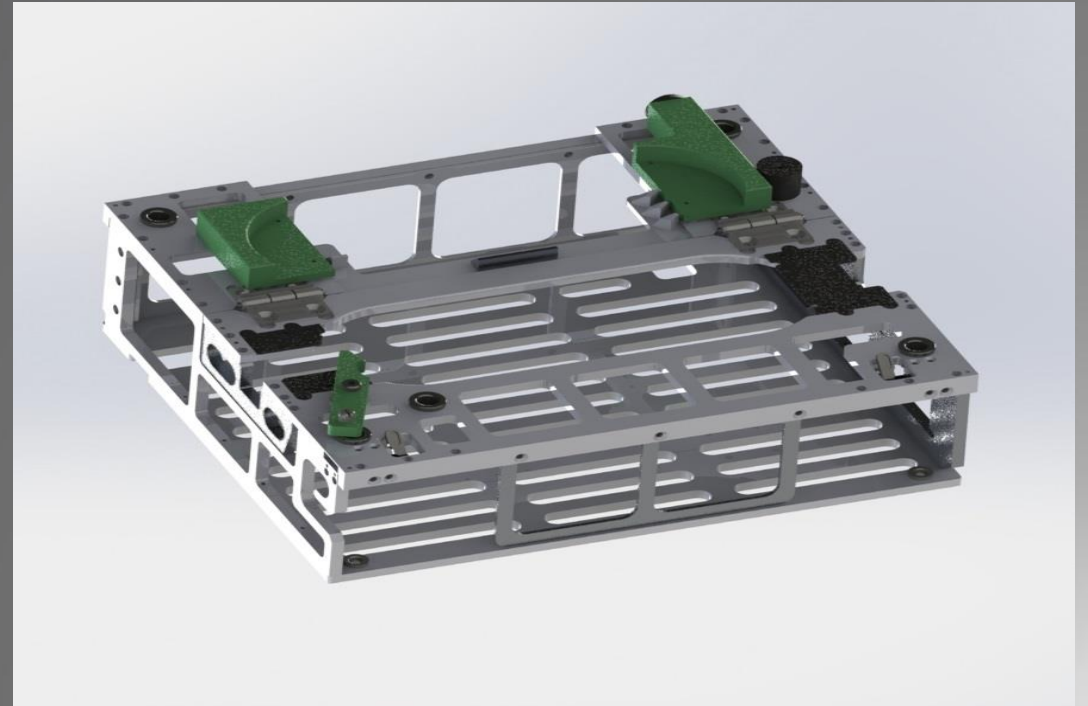

Workpiece carrier

Reference equipment

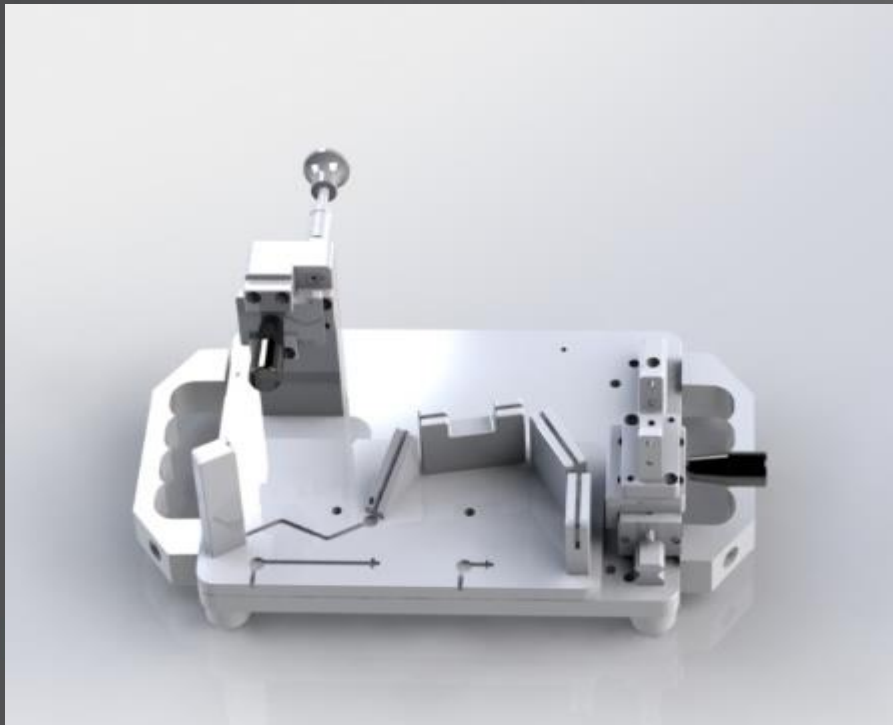

Finished product inspection and leveling
device

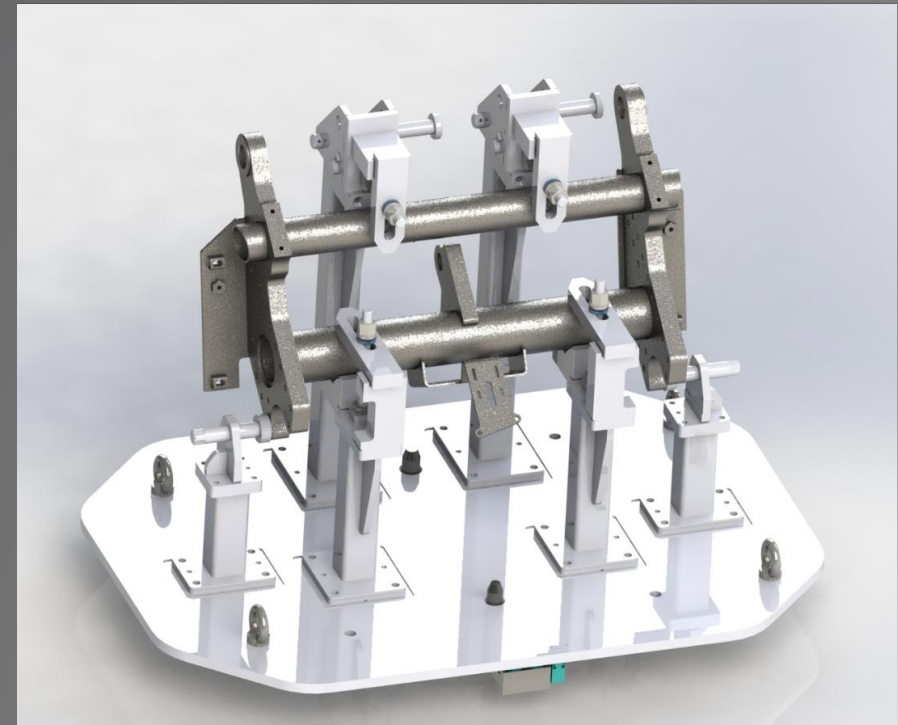

Robot welding unit

Reference equipment

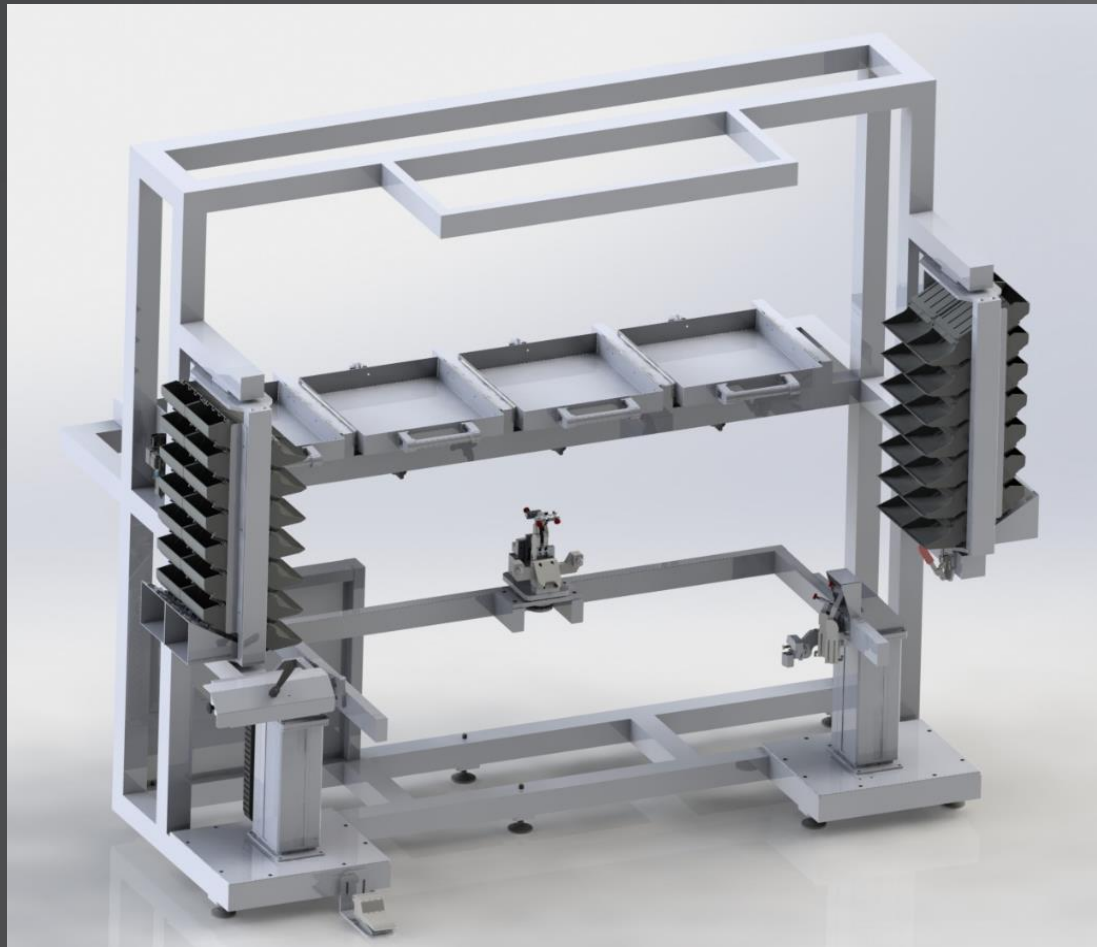

- Rotating table
- Pneumatic control
- Pneumatic changeover between types
- Pneumatic product clamping
- Parts storage boxes and pull-out drawers

Reference semiautomatic, automatic equipment

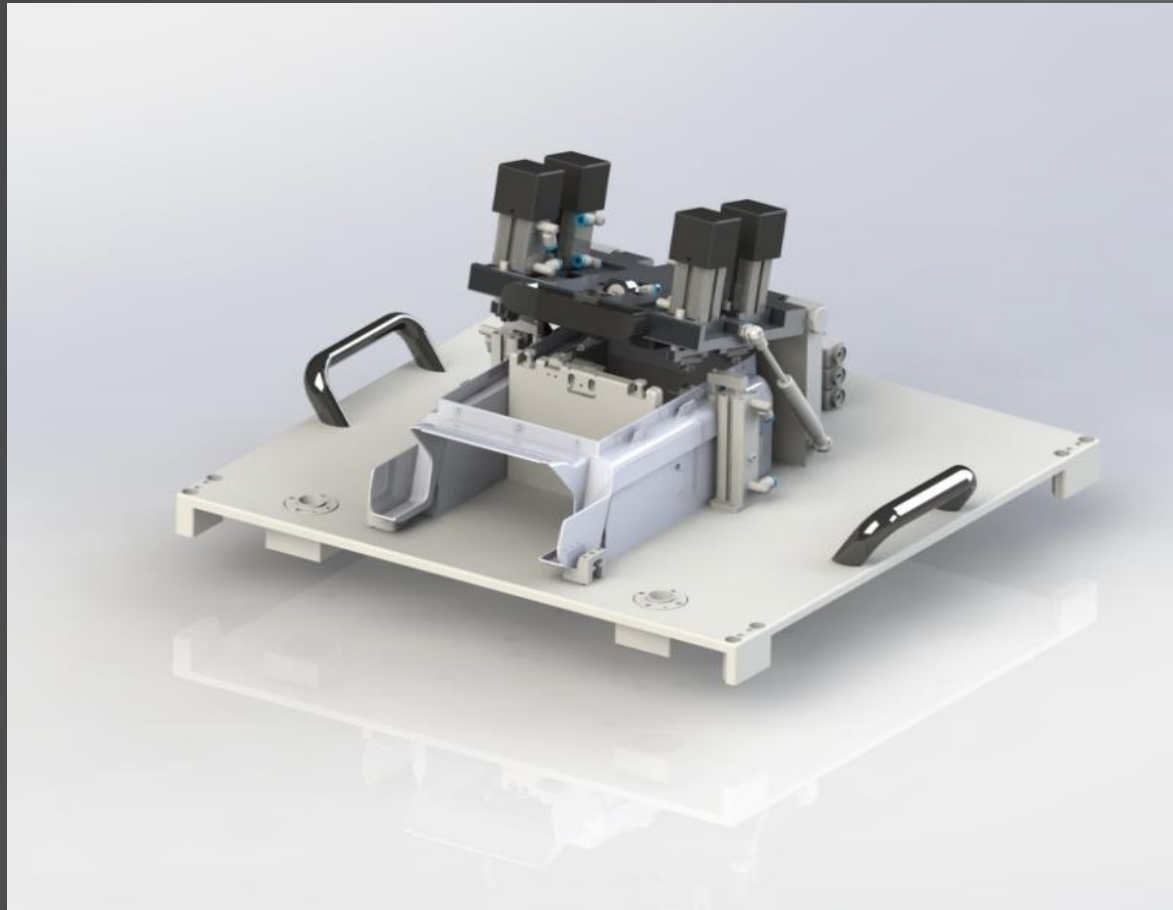

- Clips pressing equipment
- Controlled, pneumatic workpiece arrest and clips pressing

Reference semiautomatic, automatic equipment

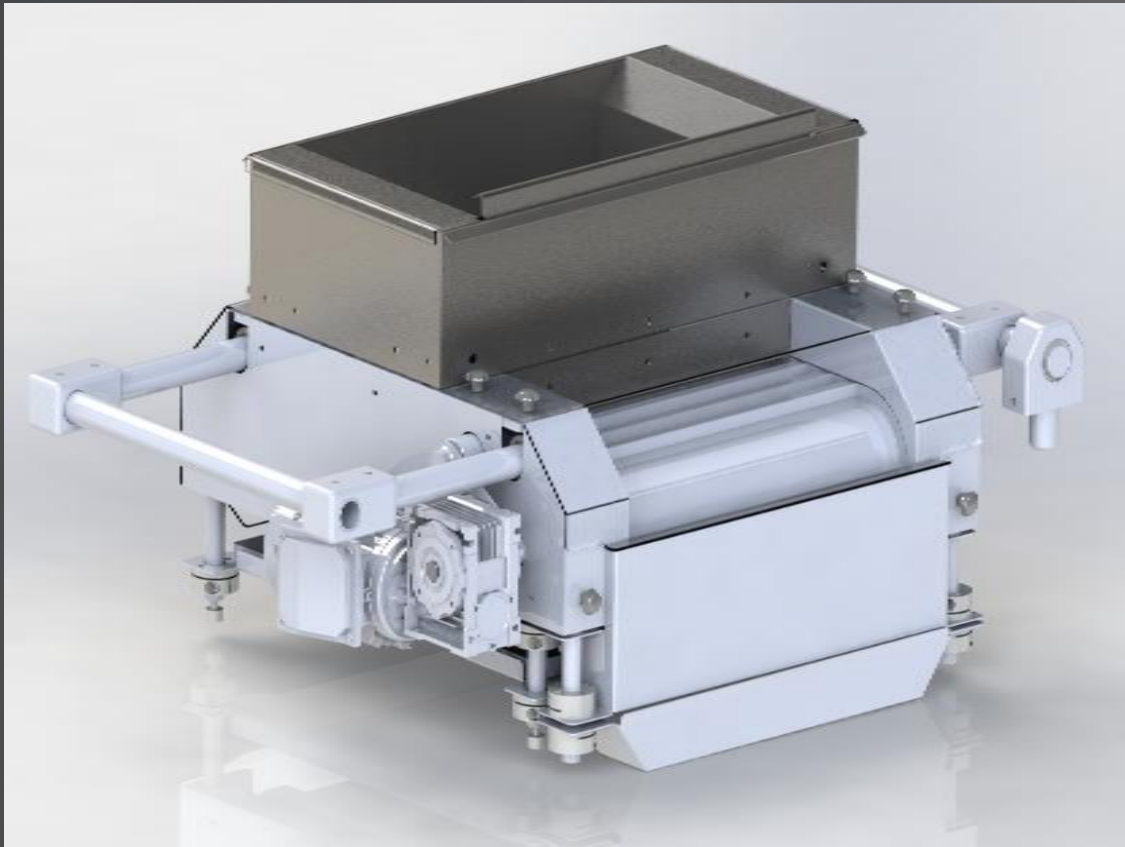

- Cheese grater dispensing track
- Continuous and intermittent mode switch
- Easy to clean

Reference semiautomatic, automatic equipment

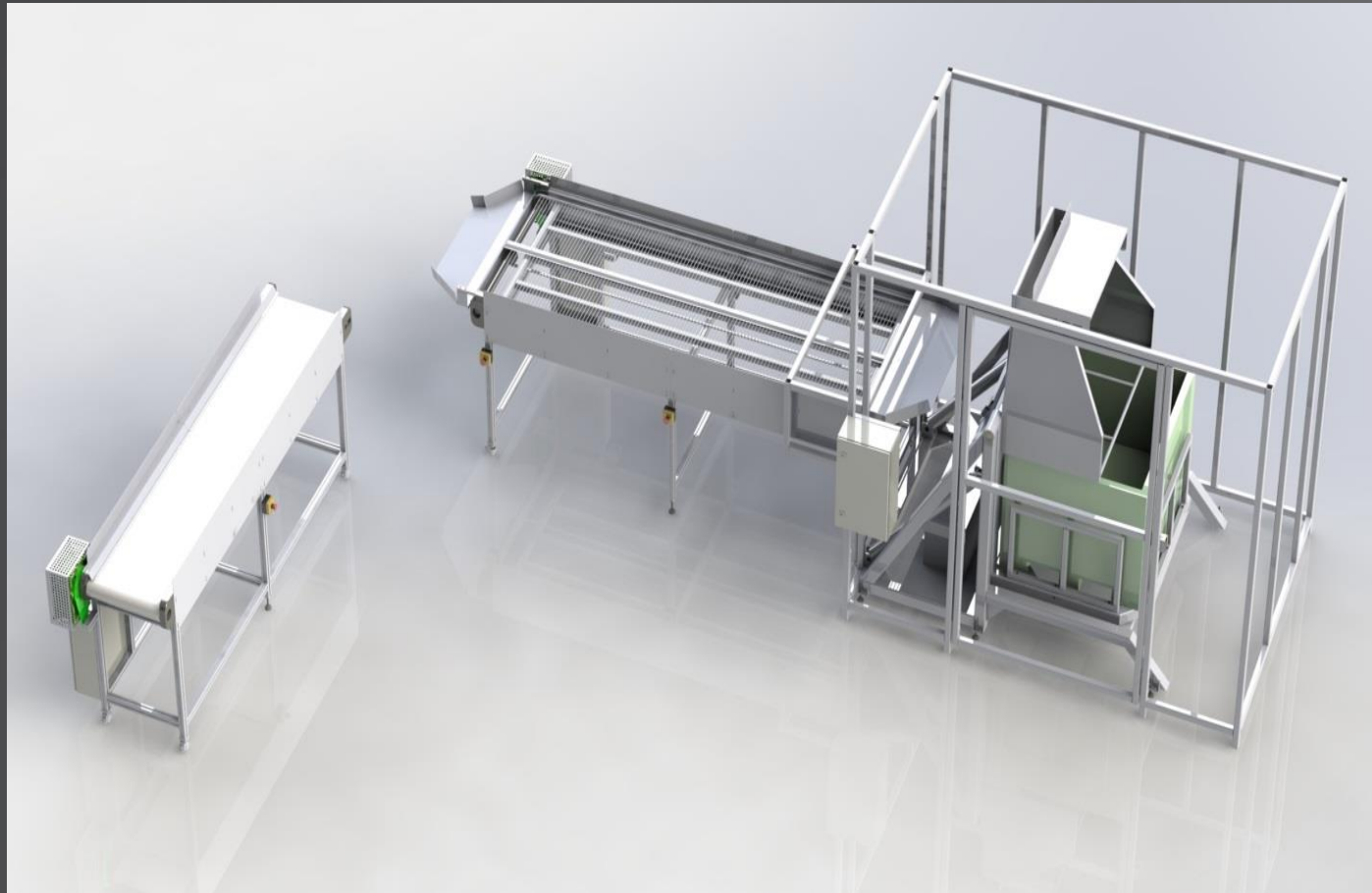

- Processing line
- Adjustable conveyor
- Hydraulic moving unit
- Connected security circles

Reference semiautomatic, automatic equipment

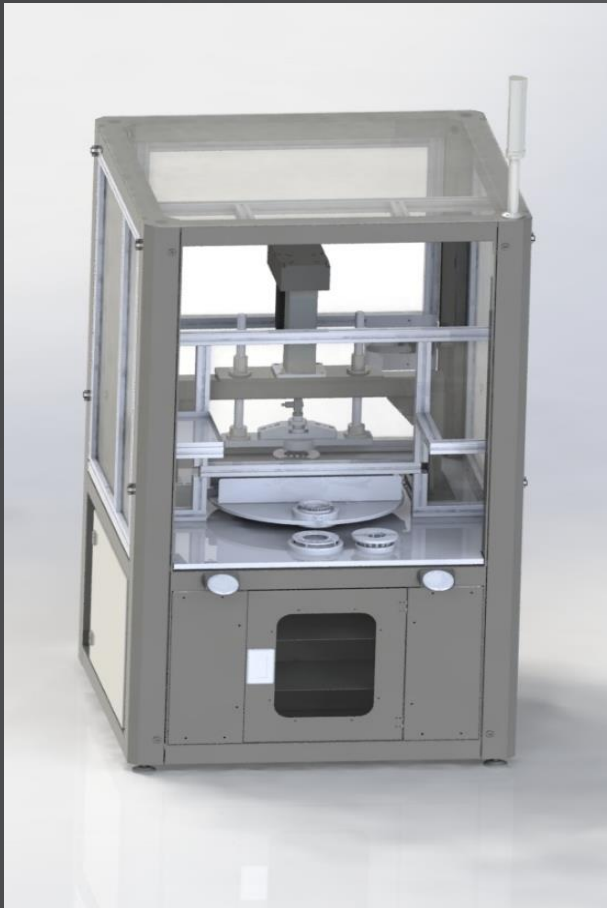

- Spring disc assembly station
- Servo press assembly with force measurement
- Manual rotary table

Reference semiautomatic, automatic equipment

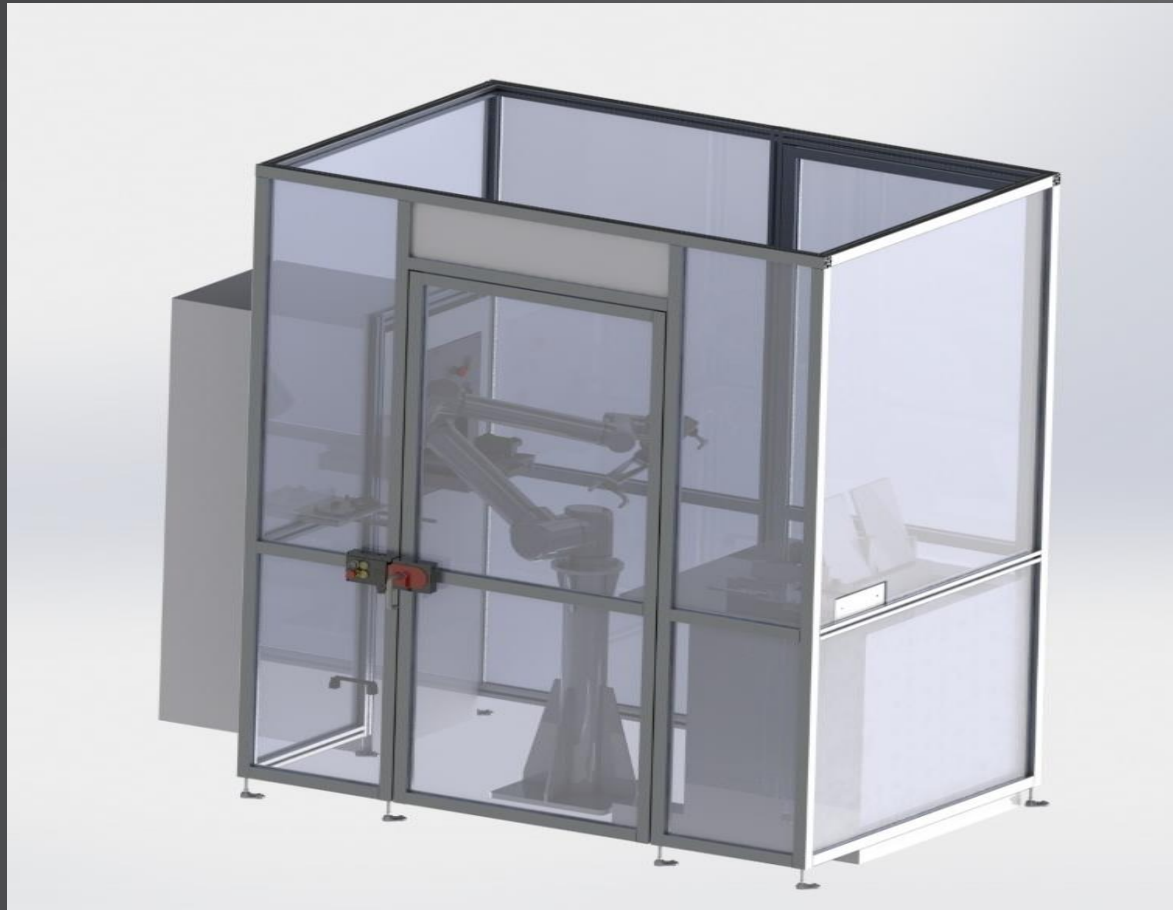

- PCB transmovement unit
- Pneumatically moved box
- Automatic packing with UR robot in internal position

Reference automatic equipment

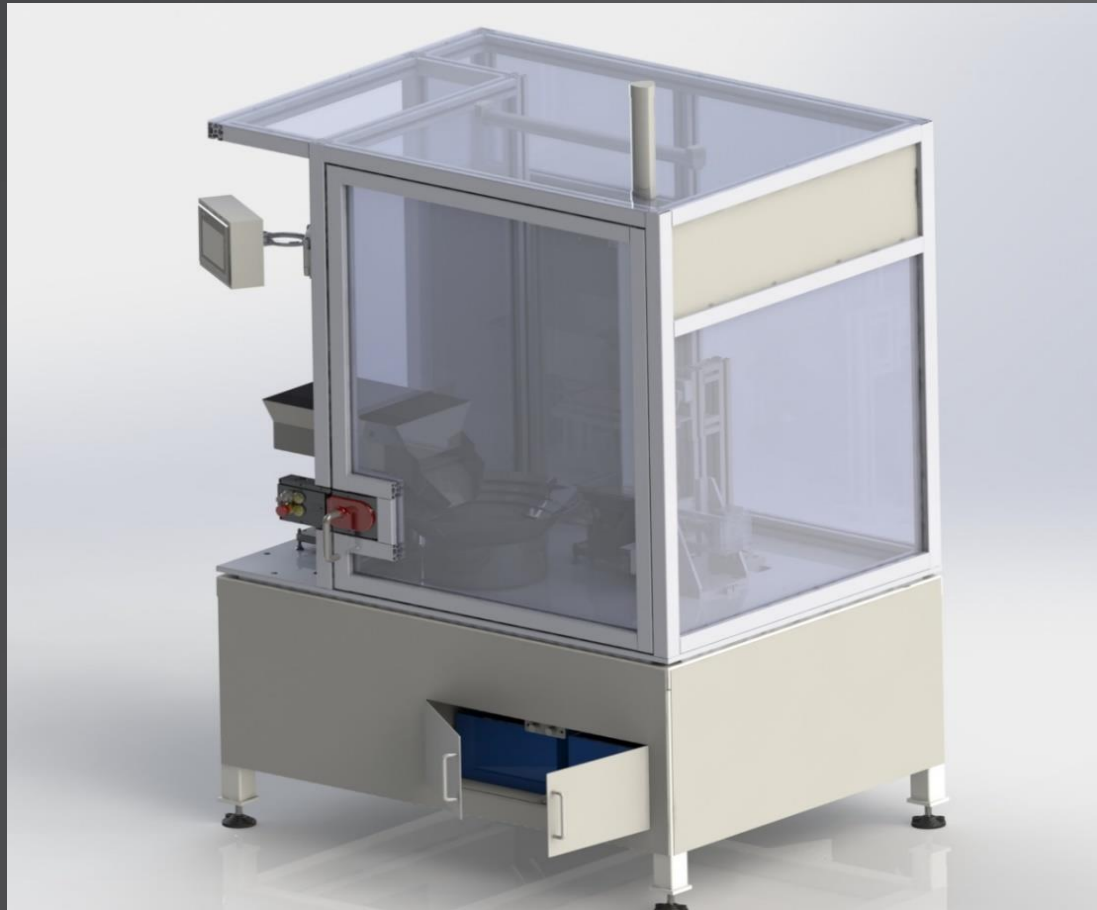

- Sorting of plastic parts
- Waste sorting and dropping
- Extension of sorting scheme
- APTIV Tatabanya projekt

Reference automatic equipment

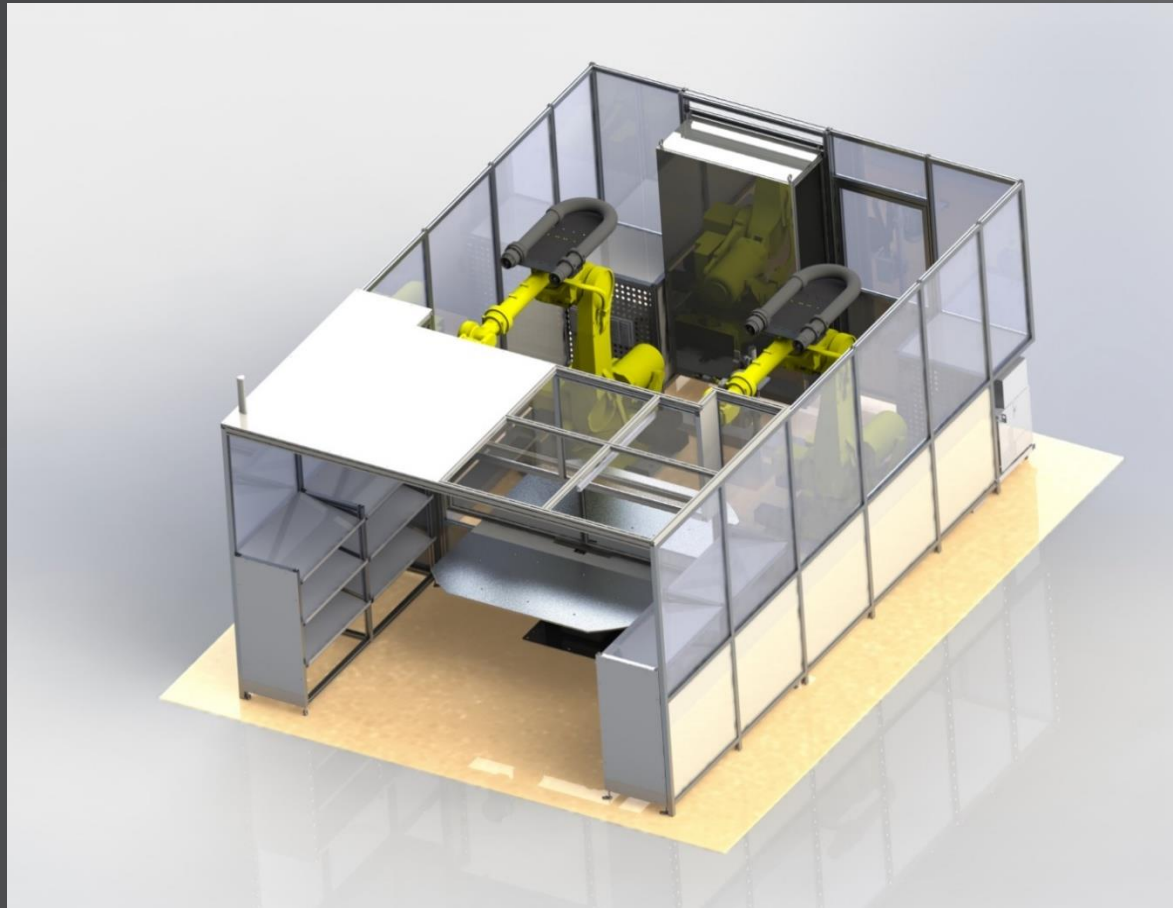

- Wireframe welding equipment
- Automatic welding in the internal position
- Handling of several types
- Appliance changing between types

Reference automatic equipment



- Wireframe welding equipment
- Automatic welding in the internal position
- Handling of several types
- Appliance changing between types

Reference automatic equipment

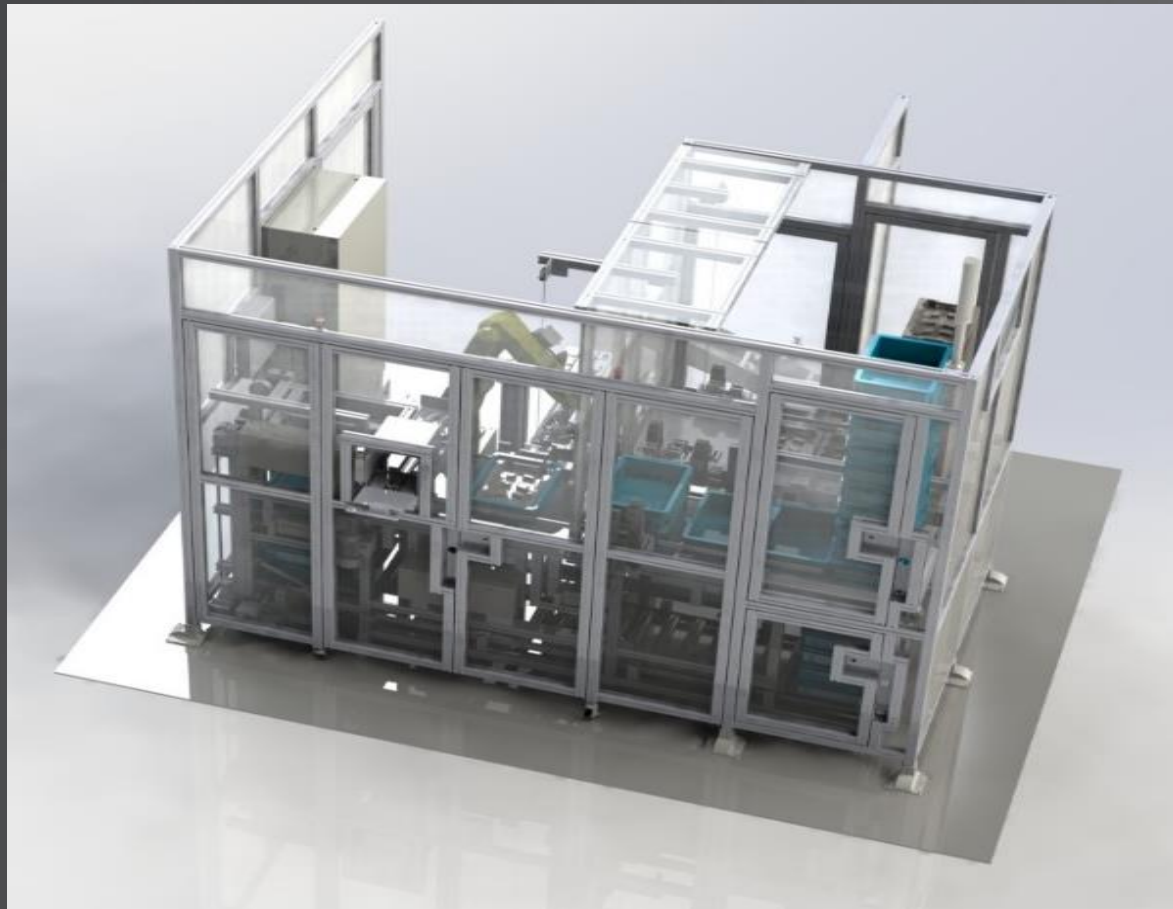

- Automatic unloading with FANUC Robot
- Plastic KLT box resp., dosage of separator palettes with deposit
- Sprue disposal, waste disposal
- APTIV Tatabanya projekt

Reference automatic equipment

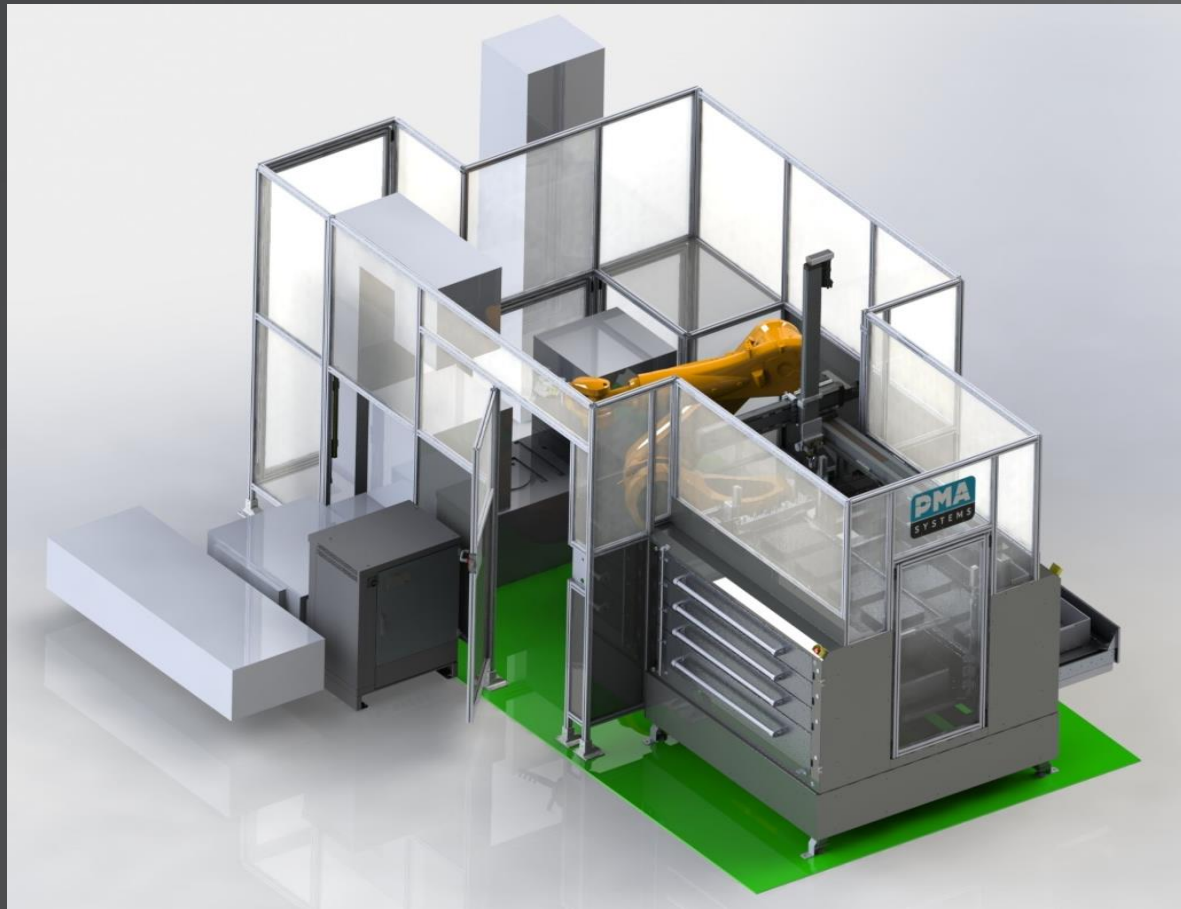

- Security drawer installation
- 3-axis manipulator unloading from drawers
- Robotic automatic transshipment
- Manually insert trays into the drawers

Reference automatic equipment

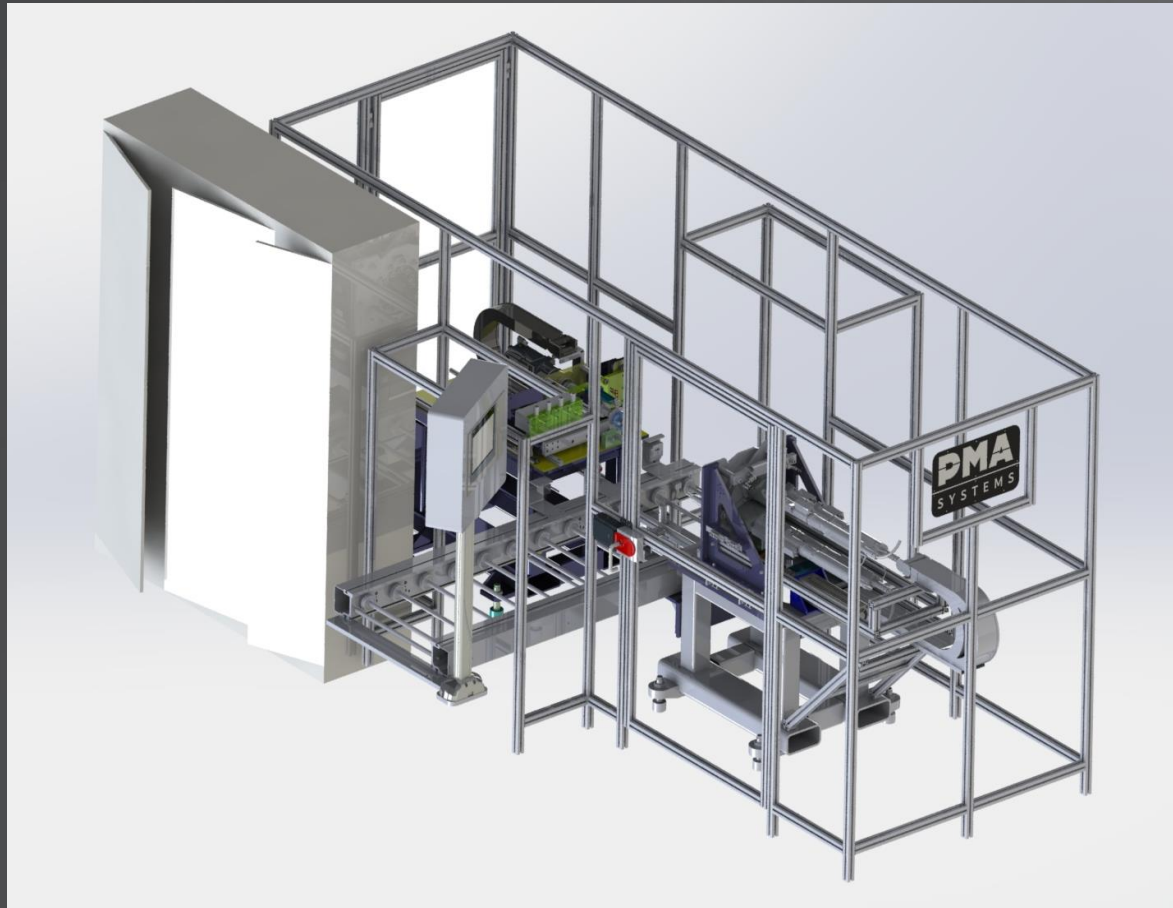

- Automatic flywheel screwing
- Automatic servo motor rotation between screws
- Transmission of torque and angle values to a central database

Reference automatic equipment



- Security drawer installation
- 3-axis manipulator unloading from drawers
- Robotic automatic transshipment
- Manually insert trays into the drawers
- APTIV Tatabanya projekt

Reference automatic equipment



- Workpiece from GIBO to overhead conveyor
- un/uploading with 5 axis robot
- Robotic automatic transshipment
- Manually insert GIBO into the robotcell

Further services

Item production

- 24 hour availability for our customers
- Own material warehouses
- Milling, turning, grinding
- Surface treatment
- 3D coordinate measuring device
- Laser engraving

Item production



Item production



Reference: component manufacturing

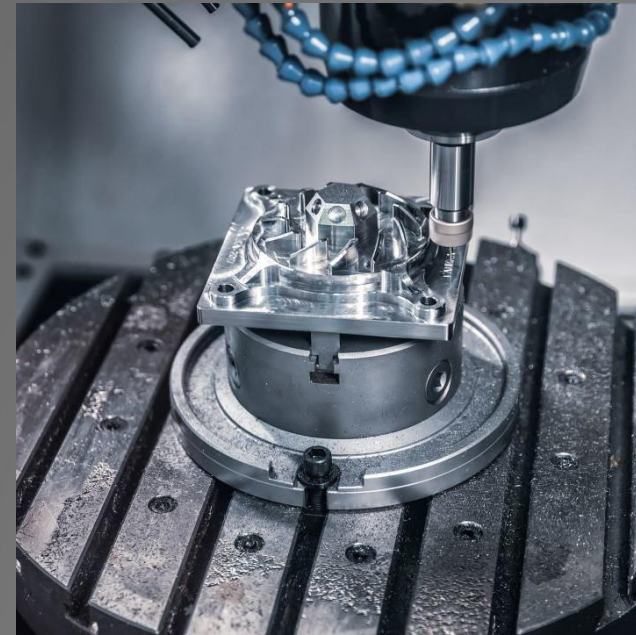

Our Customers

- Sertec Auto Structures Bt.
- BOS Automotive Products Hun. LP.
- Yanfeng Hun. Aut. Interior Sys. Kft.
- MELECS EWS GmbH Mo-i Fióktelepe
- REHAU-Automotive Kft.
- NHK Spring Hungary Kft.
- Audi Hungária Zrt.
- Aptiv Connection Systems Hun. Kft.
- Gurit Hungary Kft .
- DANA Hungary Kft.
- INZI Controls Hungary Kft.
- LORAN Kft.
- FESTO-AM Kft.
- SK On Hungary Kft.
- SK Battery Manufacturing Kft.
- Toyo Seat Europe Kft
- ThyssenKrupp Automotive System GmbH
- EATON Manufacturing Hungary Kft.
- KSH Rugógyár Bt.
- SMR Automotive Mirror Technology Hungary Bt.
- Tenneco Hungary Kft.
- Valeo Electric Magyarország Kft.
- Valeo Siemens eAutomotive Hungary Kft.
- DENSO Gyártó Magyarország Kft.

Into the future

- Expanding our partner relationships
- Expanding our production and design capacity
- More machining machines
- Development of a company management system
- Implementation of a new, modern site



Thank you very much for your attention!

